

# VS/AM 65

Spring relief valves



**TECHNICAL BROCHURE**

**Pietro Fiorentini S.p.A.**

Via E.Fermi, 8/10 | 36057 Arcugnano, Italy | +39 0444 968 511  
sales@fiorentini.com

The data are not binding. We reserve the right  
to make changes without prior notice.

vsam65\_technicalbrochure\_ENG\_revA

**[www.fiorentini.com](http://www.fiorentini.com)**

# Who we are

We are a global organization that specializes in designing and manufacturing technologically advanced solutions for natural gas treatment, transmission and distribution systems.

We are the ideal partner for operators in the Oil & Gas sector, with a business solutions that span the whole natural gas chain.

We are constantly evolving to meet our customers' highest expectations in terms of quality and reliability.

Our aim is to be a step ahead of the competition, with customized technologies and an after-sale service program undertaken with the highest level of professionalism.



## Pietro Fiorentini advantages



Localised technical support



Experience since 1940



Operating in over 100 countries

# Area of Application

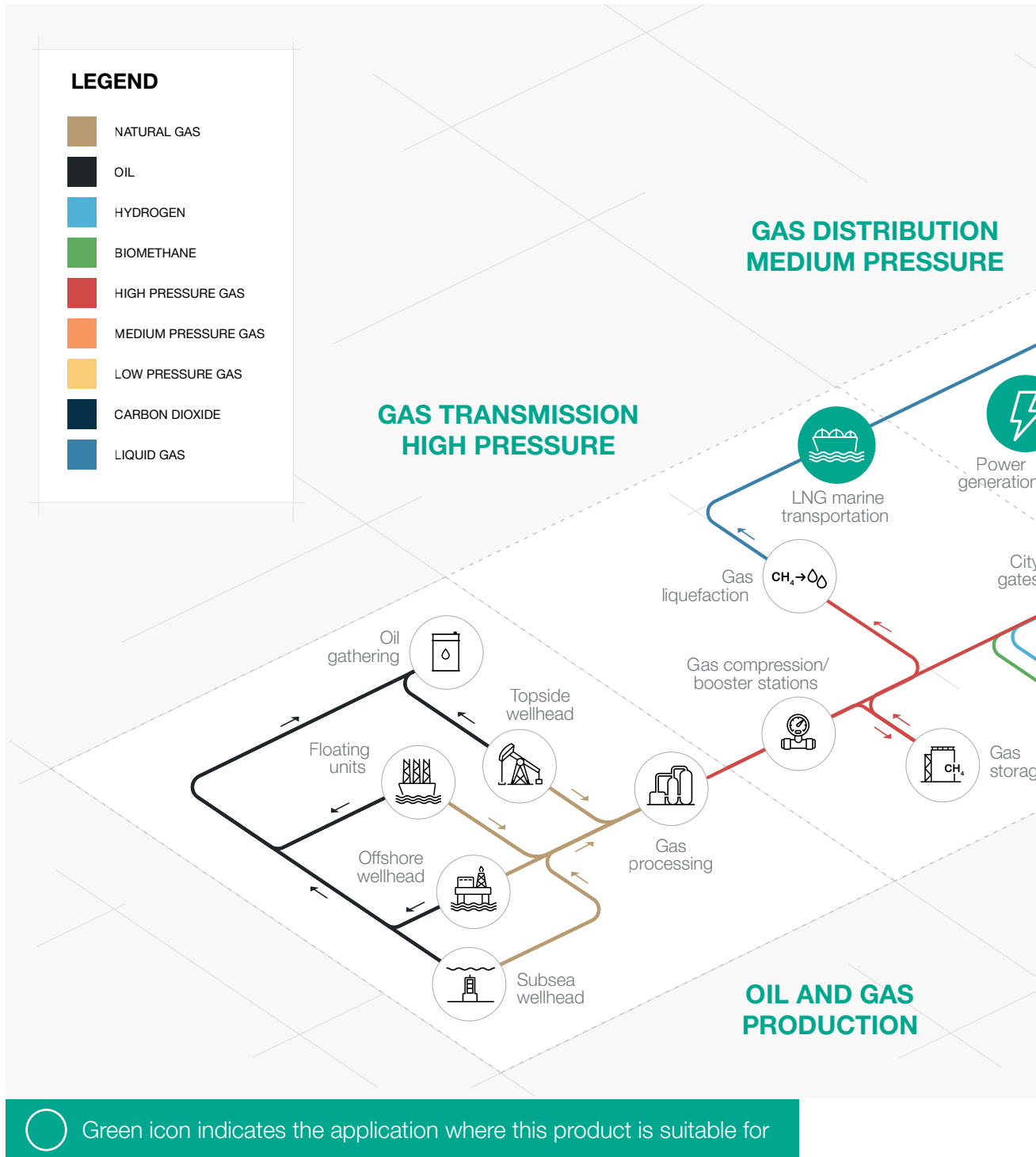

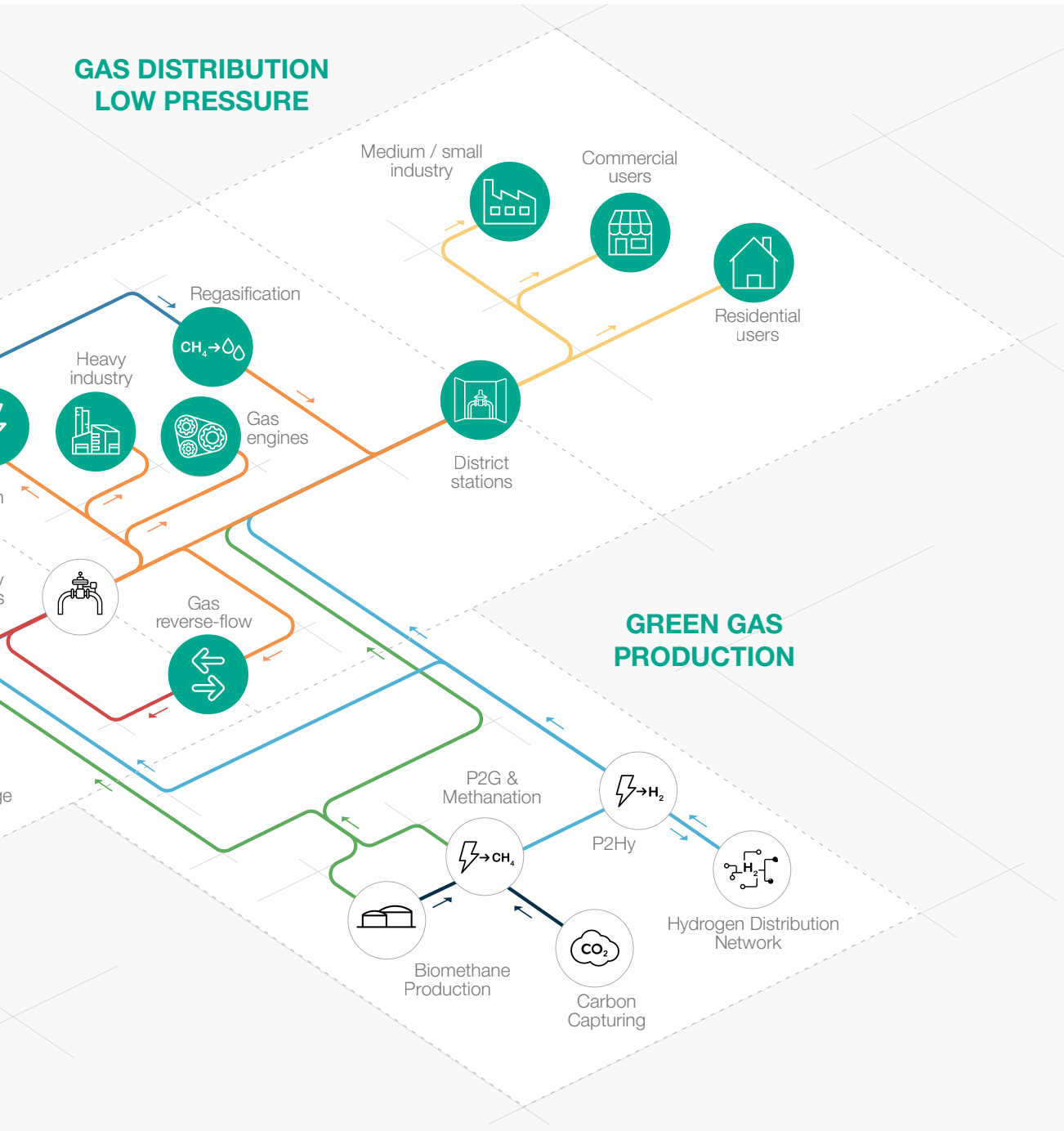

**Figure 1** Area of Application Map

# Introduction

The **VS/AM 65** by Pietro Fiorentini is a relief valve which vents gas when the system pressure exceeds the set value due to temporary events.

During no-flow conditions, thermal expansion of the gas can cause downstream static pressure to build up. The relief valve **will prevent downstream pressure from rising** due to gas temperature change, downstream pressure shocks caused by sudden changes of flow or eventually regulator's lock-up failure.

Particularly suitable in high-pressure transmission systems and in medium pressure gas distribution networks.

It should to be used with previously filtered non-corrosive gases.

The VS/AM 65 is **Hydrogen Ready** for NG-H2 blending.

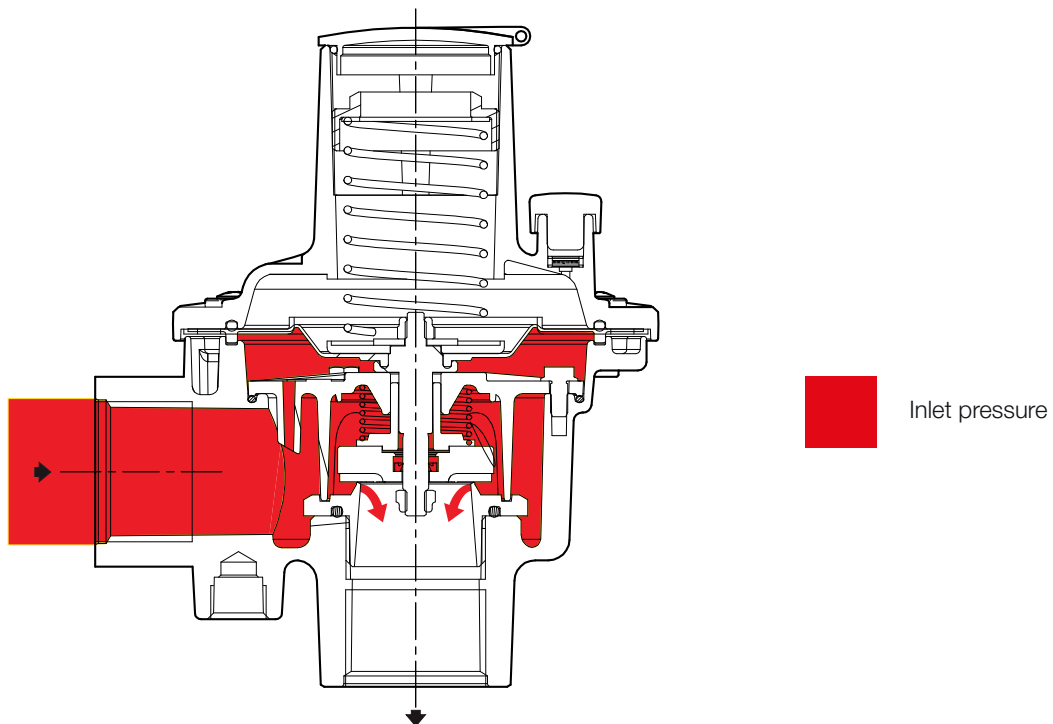

**Figure 2** VS/AM 65

# Features

The VS/AM 65 safety device operates with the principle of comparing the thrust on the piston and the pressure of the gas to be controlled.

When the thrust resulting from the gas pressure exceeds that one generated by the springs, the plug is raised and a certain amount of gas is discharged. Otherwise, the plug is released and closes the valve seat by the effect of the gas pressure to be controlled and the pre-setting spring.

This feature prevents damages from mishandling the set-point adjusting nut.

The VS/AM 65 is a fast response safety device and offer the possibility to seal the adjustment nut to prevent unauthorised access.

## VS/AM 65 competitive advantages



Compact dimensions



Fast response



Easy maintenance



Limit switch option (BLD 211)



Adjustment nut sealing



Biomethane compatible and  
20% Hydrogen blending compatible.  
Higher blending available on request

## Features

Features	Values
Design pressure*	up to 2 MPa up to 20 barg
Ambient temperature*	from -20 °C to +60 °C from -4 °F to +140 °F
Gas temperature*	from -20 °C to +60 °C from -4 °F to +140 °F
Available accessories	Limit switch BLD 211
Maximum allowable overpressure	<ul style="list-style-type: none"> <li>50 kPa for BP, 100 kPa for MP, 1 MPa for TR</li> <li>500 mbar for BP, 1 barg for MP, 10 barg for TR</li> </ul>
Setting range (Who)	<ul style="list-style-type: none"> <li>from 1.5 to 15 kPa for BP, from 15 to 50 kPa for MP, from 50 to 700 kPa for TR</li> <li>from 15 to 150 mbar for BP, from 150 to 500 mbar for MP, from 0.5 to 7 barg for TR</li> </ul>
Accuracy	up to 2.5% (depending on model and setting pressure)
Nominal size	DN 25 / 1"
Connections	<ul style="list-style-type: none"> <li>Threaded EN 10226-1</li> <li>NPT according to ASME B1.20.1</li> <li>ANSI 150 according to ASME B16.5</li> </ul>

(\* NOTE: Different functional features and/or extended temperature ranges may be available on request. Stated inlet gas temperature range is the maximum for which the equipment's full performance, including accuracy is guaranteed. Product may have a different pressure or temperature ranges according to the version and/or installed accessories.

**Table 1** Features



# Materials and Approvals

Part	Material
Body	Aluminium

**NOTE:** The materials indicated above refer to the standard models. Different materials can be provided according to specific needs.

**Table 2** Materials

## Construction Standards and Approvals

The **VS/AM 65** spring relief valve is designed according to the European standard EN 14382. The product is certified according to European Directive 2014/68/EU (PED).

Leakage class: bubble tight, better than class VI according to ANSI/FCI 70-2 and equivalent to class VIII according to ANSI/FCI 70-3.



EN 14382



PED-CE



# Spring ranges

Control heads pressure ranges				
	Control head BP	Control head MP	Control head TR	Spring Table web link
Model	kPa mbar	kPa mbar	kPa mbar	
VS/AM 65	1.5 ÷ 14.9 15 ÷ 149	15 ÷ 49.9 150 ÷ 499	50 ÷ 700 500 ÷ 7000	<a href="#">IT 00504</a>

**Table 3** VS/AM 65 spring ranges

General link to the calibration tables: [PRESS HERE](#) or use the QR code:



# Weights and Dimensions

## VS/AM 65

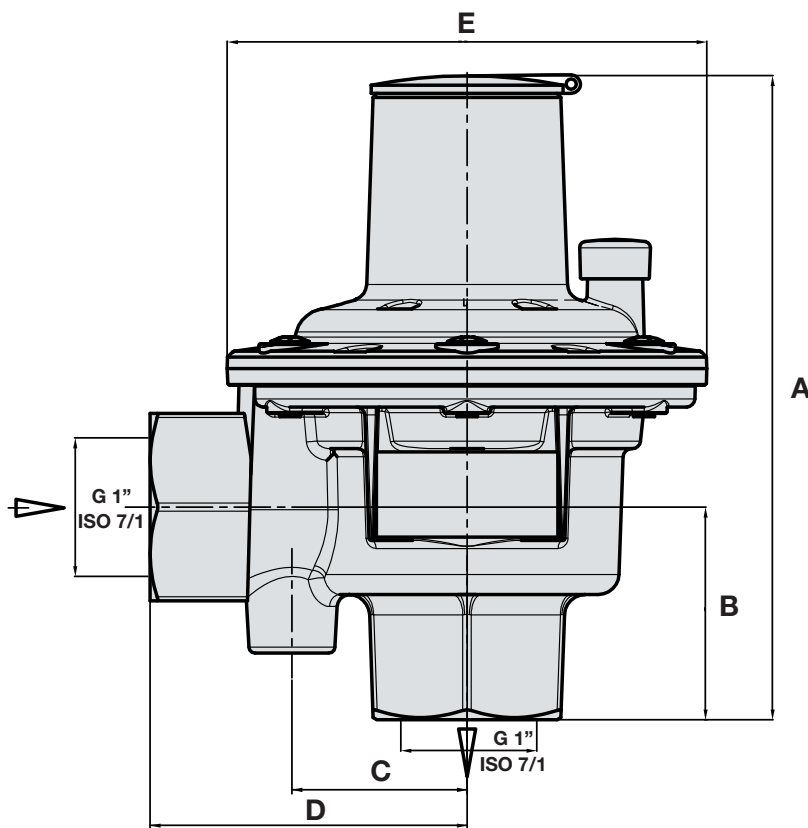

**Figure 3** VS/AM 65 dimensions

Weights and Dimensions (for other connections please contact your closest Pietro Fiorentini representative)		
	[mm]	inches
A	155	6.1"
B	51	2.0"
C	42	1.7"
D	76	3.0"
E	115	4.5"
<b>Weight</b>		
	Kg	lbs
BP	1.4	3.1
MP	1.4	3.1
TR	1.7	3.7

**Table 4** Weights and dimensions



# Sizing

In general, the choice of a relief valve is made of several factors, but primarily by the relation between the gas discharge capacity and the setting pressure.

To ease the selection the table below gives the values of the discharge flow for various overpressures in relation to the setting. For intermediate values, the flow can be calculated by linear interpolation.

Natural gas flow (d=0.61) in Nm <sup>3</sup> /h												
	Set-ting	Bubble bur- sting	5	10	15	20	25	30	35	40	45	50
Overpressure in relation to setting in %												
kPa	2	2	8	13	14	15	16	16.5	17	17.4	17.8	18
	8	8	4	12	15	115	120	124	126	128	129	130
	40	40	15	75	130	250	320	335	340	345	348	350
	360	360	14	130	140	1100	1280	1285	1290	1295	1298	1300
mbar	20	20	8	13	14	15	16	16.5	17	17.4	17.8	18
	80	80	4	12	15	115	120	124	126	128	129	130
	400	400	15	75	130	250	320	335	340	345	348	350
	3600	3600	14	130	140	1100	1280	1285	1290	1295	1298	1300
	6000	6000	14	80	250	1300	1310	1320	1330	1340	1345	1350

**Table 5** Natural gas flow

The VS/AM 65 full calculation of the discharge flow rate can be determined using formulas and flow coefficients below.

**Metric system formula:**

$$q = (0.9 \cdot K_c) \cdot (394.9 \cdot C) \cdot P_1 \cdot A \cdot \sqrt{\frac{M}{Z_1 \cdot T_1}} \quad Q = 23.661 \cdot \frac{q}{M}$$

Where:

q	Maximum discharged flowrate [ kg/h ]
C	Expansion coefficient
P <sub>1</sub>	Calibration pressure ( p <sub>st</sub> ) plus 10% in absolute bar
A	Crossing minimum surface [ cm <sup>2</sup> ] (see Table 6)
Q	Maximum flowrate [ Stm <sup>3</sup> /h ]
M	Molecular weight of fluid [ kg/kmol ] (see Table 7)
Z <sub>1</sub>	Compressibility factor of the fluid drain conditions ( = 1 if unknown)
T <sub>1</sub>	Temperature of fluid at valve inlet [ K ]
k=	Isentropic equation coefficient
K <sub>c</sub>	Discharged coefficient

### Imperial system formula:

$$q = (0.9 \cdot K_c) \cdot (38773 \cdot C) \cdot P_1 \cdot A \cdot \sqrt{\frac{M \cdot 0.453}{Z_1 \cdot (0.555 \cdot T_1) + 255.37}} \quad Q = 23.661 \cdot \frac{q}{M}$$

Where:

q	Maximum discharged flowrate [ lbs/h ]
C	Expansion coefficient
P <sub>1</sub>	Calibration pressure (p <sub>st</sub> ) plus 10% [ psi abs ]
A	Crossing minimum surface [ in <sup>2</sup> ] (see Table 6)
Q	Maximum flowrate [ scfh ]
M	Molecular weight of fluid [ lbs/kmol ] (see Table 7)
Z <sub>1</sub>	Compressibility factor of the fluid drain conditions ( = 1 if unknown)
T <sub>1</sub>	Temperature of fluid at valve inlet [ °F ]
k=	Isentropic equation coefficient
K <sub>c</sub>	Discharged coefficient

### Calculation of the flow coefficient

<b>Millimetres</b>	25
<b>Inches</b>	1"
<b>Minimum diameter [cm]</b>	2.3
<b>Minimum diameter [in]</b>	0.9"
<b>Minimum passage area [cm<sup>2</sup>]</b>	4.1548
<b>Minimum passage area [in<sup>2</sup>]</b>	0.64"

**Table 6** Calculation of the flow coefficient

### Molecular weight and expansion coefficient

Fluid type	Molecular mass (kg/kmol)	Molecular mass (lbs/kmol)	Expansion coefficient C
Carbon dioxide	44.01	97.03	2.637
Hydrogen	2.02	4.45	2.708
Methane	16.04	35.36	2.641
Natural gas*	18.04	39.77	2.641
Nitrogen	28.02	61.77	2.704
Oxygen	32.00	70.55	2.704
Propane	44.09	97.20	2.507

(\*) average value

**Table 7** Molecular weight and expansion coefficient



# Customer Centricity

Customer centricity is a way of running your business — implementing a perfect customer experience at each stage of the pipeline. Pietro Fiorentini is one of the main Italian international company with high focus on product and service quality.

The main strategy is to create a stable, long-term relationship, putting the customer's needs first. Lean management and customer centricity are used to improve and maintain the highest level of customer experience.



## Support

Pietro Fiorentini's top priority is to provide support to the client in all phases of project development, during installation, start up and operation. Pietro Fiorentini has developed a highly standardized Intervention-Management-System (IMS), which helps to facilitate the entire process and putting the customer at the forefront of every decision in our process while manufacturing or developing a product to help improve the product and service. With our IMS business model many services are available remotely, avoiding long waiting times, improving service, and avoiding unnecessary expenses.



## Training

Pietro Fiorentini offers training services available for both experienced operators and new customers. The training is offered for all levels of our customers which can include one or all of the following: sizing of equipment, application, installation, operation, maintenance and is prepared according to the level of use and the customer's need.



## Customer Relation Management (CRM)

The service and care of our customers are one of the main missions and vision of Pietro Fiorentini. For this reason, Pietro Fiorentini has enhanced the customer relation management system. This enables us to track every opportunity and request from our customers into one single information point and allows us to coordinate information allowing us to give the customer improved service.

# Sustainability

Here at Pietro Fiorentini, we believe in a world capable of improvement through technology and solutions that can shape a more sustainable future. That is why respect for people, society and the environment form the cornerstones of our strategy.



## Our commitment to the world of tomorrow

While in the past we limited ourselves to providing products, systems and services for the oil & gas sector, today we want to broaden our horizons and create technologies and solutions for a digital and sustainable world. We have a particular focus on renewable energy projects to help make the most of our planet's resources and create a future in which the younger generations can grow and prosper.

The time has come to understand how and why we operate now.





# Pietro Fiorentini

**TB0050ENG**



The data are not binding. We reserve the right  
to make changes without prior notice.

vsam65\_technicalbrochure\_ENG\_revA

[www.fiorentini.com](http://www.fiorentini.com)